

OPERATING INSTRUCTIONS

WIRELESS MICROPHONE SYSTEM S4.04 / S4.10 series

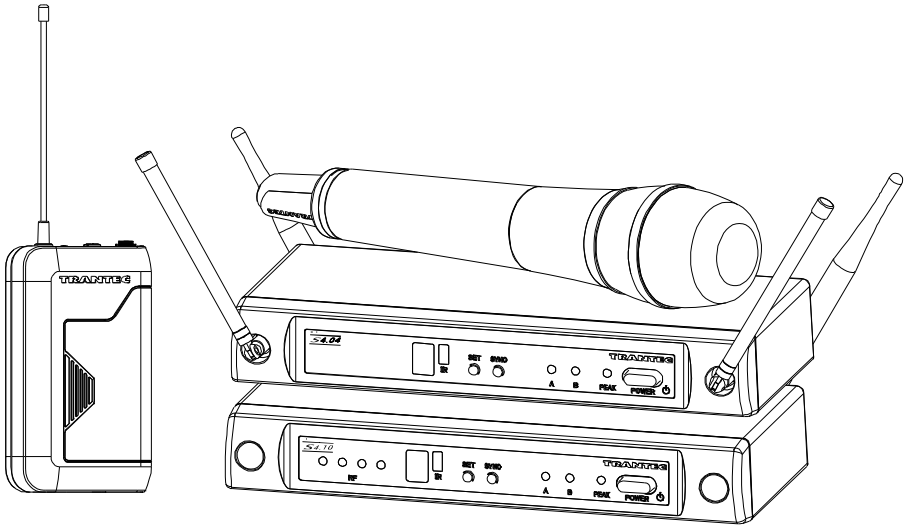

CONTENTS

- | | |
|--|-----------------------|
| 1. SAFETY PRECAUTIONS | 8. CHANNEL SCAN |
| 2. GENERAL DESCRIPTION | 9. BATTERY ALARM |
| 3. FEATURES | 10. OPERATIONAL HINTS |
| 4. HANDLING PRECAUTIONS | 11. TROUBLESHOOTING |
| 5. NOMENCLATURE AND FUNCTIONS | 12. SPECIFICATIONS |
| 6. CHANNEL NUMBER SETTING by MANUAL | |
| 7. CHANNEL NUMBER SETTING by
INFRARED SYNCHRONIZATION | |

Thank you for purchasing TOA's TRANTEC S4 series Wireless Microphone system.
Please carefully follow the instructions in this manual to ensure long, trouble-free use of your equipment.

1. SAFETY PRECAUTIONS

- Be sure to read the instructions in this section carefully before use.
- Make sure to observe the instructions in this manual as the conventions of safety symbols and messages regarded as very important precautions are included.
- We also recommend you keep this instruction manual handy for future reference.

Safety Symbol and Message Conventions

Safety symbols and messages described below are used in this manual to prevent bodily injury and property damage which could result from mishandling. Before operating your product, read this manual first and understand the safety symbols and messages so you are thoroughly aware of the potential safety hazards.



WARNING

Indicates a potentially hazardous situation which, if mishandled, could result in death or serious personal injury.

When Installing the Receiver

- Do not expose the unit to rain or an environment where it may be splashed by water or other liquids, as doing so may result in fire or electric shock.
- Use the unit only with the voltage specified on the unit. Using a voltage higher than that which is specified may result in fire or electric shock.
- Do not cut, kink, otherwise damage nor modify the power supply cord. In addition, avoid using the power cord in close proximity to heaters, and never place heavy objects -- including the unit itself -- on the power cord, as doing so may result in fire or electric shock.
- Avoid installing or mounting the unit in unstable locations, such as on a rickety table or a slanted surface. Doing so may result in the unit falling down and causing personal injury and/or property damage.
- To prevent lightning strikes, install the unit at least five meters away from a lightning rod, and yet within the protective range (angle of 45°) of the lightning conductor. Lightning strikes may cause a fire, electric shock or personal injury.
- Since the unit is designed for in-door use, do not install it outdoors. If installed outdoors, the aging of parts causes the unit to fall off, resulting in personal injury. Also, when it gets wet with rain, there is a danger of electric shock.

When the Receiver is in Use

- Should the following irregularity be found during use, immediately switch off the power, disconnect the power supply plug from the AC outlet and contact your nearest TOA dealer. Make no further attempt to operate the unit in this condition as this may cause fire or electric shock.
 - If you detect smoke or a strange smell coming from the unit.
 - If water or any metallic object gets into the unit
 - If the unit falls, or the unit case breaks
 - If the power supply cord is damaged (exposure of the core, disconnection, etc.)
 - If it is malfunctioning (no tone sounds.)
- Do not place cups, bowls, or other containers of liquid or metallic objects on top of the unit. If they accidentally spill into the unit, this may cause a fire or electric shock.
- Do not touch the unit's antennas during thunder and lightning, as this may result in electric shock.

When the Microphone or the Transmitter is in Use

- To prevent the electromagnetic wave from badly influencing medical equipment, make sure to switch off the unit's power when placing it in close proximity to the medical equipment



CAUTION

Indicates a potentially hazardous situation which, if mishandled, could result in moderate or minor personal injury, and/or property damage.

When Installing the Receiver

- Never plug in nor remove the power supply plug with wet hands, as doing so may cause electric shock.
- When unplugging the power supply cord, be sure to grasp the power supply plug; never pull on the cord itself. Operating the unit with a damaged power supply cord may cause a fire or electric shock.
- When moving the unit, be sure to remove its power supply cord from the wall outlet. Moving the unit with the power cord connected to the outlet may cause damage to the power cord, resulting in fire or electric shock. When removing the power cord, be sure to hold its plug to pull.
- The socket outlet shall be installed near the equipment and shall be easily accessible.
- Avoid installing the unit in humid or dusty locations, in locations exposed to the direct sunlight, near the heaters, or in locations generating sooty smoke or steam as doing otherwise may result in fire or electric shock.

When the Receiver is in Use

- Do not place heavy objects on the unit as this may cause it to fall or break which may result in personal injury and/or property damage. In addition, the object itself may fall off and cause injury and/or damage.
- Make sure that the volume control is set to minimum position before power is switched on. Loud noise produced at high volume when power is switched on can impair hearing.
- Never open the unit case as there are high temperature parts inside the unit, which may cause a burn if touched. Refer all servicing to your nearest TOA dealer.
- Use the dedicated AC adapter for the unit. Note that the use of other adapter may cause a fire.
- If dust accumulates on the power supply plug or in the wall AC outlet, a fire may result. Clean it periodically. In addition, insert the plug in the wall outlet securely.
- Switch off the power, and unplug the power supply plug from the AC outlet for safety purposes when cleaning or leaving the unit unused for 10 days or more. A fire or electric shock may result.
- Any modifications made to this device that are not approved by TOA Corporation may void the authority granted to the user to operate this equipment.
- Operation of this device is subject to the following two conditions: (1) this device may not cause interference, and (2) this device must accept any interference, including interference that may cause undesired operation of the device.

When the Microphone or the Transmitter is in Use

- When the unit is not in use for 10 days or more, be sure to take the battery out of the unit because battery leakage may cause personal injury or contamination of environment.
- Make sure to observe the following handling precautions so that a fire or personal injury does not result from leakage or explosion of the battery.
 - Do not short, disassemble heat nor put the battery into a fire.
 - Do not solder a battery directly.
 - Be sure to use the specified type of battery
 - Note correct polarity (positive and negative orientation) when inserting a battery in the unit.
 - Avoid locations exposed to the direct sunlight, high temperature and high humidity when storing batteries.
- When the battery becomes inflated or leaks, discontinue use and replace with new one immediately.

CAUTION TO USER: Changes or modifications not expressly approved by the party responsible for compliance could void the user's authority to operate the equipment.

IMPORTANT NOTE: To comply with the FCC RF exposure compliance requirements, no change to the antenna or the device is permitted. Any change to the antenna or the device could result in the device exceeding the RF exposure requirements and void user's authority to operate the device.

IMPORTANT NOTE:

This device complies with Industry Canada's licence-exempt RSSs. Operation is subject to the following two conditions:

(1) This device may not cause interference; and (2) this device must accept any interference, including interference that may cause undesired operation of the device.

Le présent appareil est conforme aux CNR d'Industrie Canada applicables aux appareils radio exempts de licence. L'exploitation est autorisée aux deux conditions suivantes : (1) l'appareil ne doit pas produire de brouillage, et (2) l'utilisateur de l'appareil doit accepter tout brouillage radioélectrique subi, même si le brouillage est susceptible d'en compromettre le fonctionnement.

2. GENERAL DESCRIPTION

The TOA's TRANTEC S4 series Wireless Microphone system is designed for use on the UHF frequency band, and suitable for vocal or speech reinforcement applications. It features a compander circuit which minimizes the influence of ambient noise.

S4.04 : 4 User selectable channels that can be operated simultaneously.

S4.10 : Up to 16 User selectable channels that can be operated simultaneously. (depending on region)

S4 series HDX Wireless handheld Microphone is a vocal microphone, employing a fine, powerful dynamic microphone unit.

S4 series BTX Wireless belt-pack transmitter can use TRANTEC series lavalier microphones and headset microphones.

S4 series RX Wireless receiver is a diversity receiver to minimize drop-outs.

3. FEATURES

- An optimized PLL-synthesizer minimizes the oscillation frequency drift resulting from the ambient temperature or voltage fluctuation.
- Power/Battery lamps indicate battery consumption to prevent the unit from malfunctioning when the battery level remarkably decreases.
- Up to 10 hours of continuous use with single AA alkaline battery.
- S4 series HDX employs a built-in antenna.
- The state of battery consumption can be displayed on S4 series RX receiver's indicator.
- Quick channel scanning and auto channel set-up.
- Infra-red auto channel set-up.
- Compact size and high reliability.

4. HANDLING PRECAUTIONS

- Do not expose the unit to rain or an environment where it may be splashed by water or other liquids, as doing so may result in unit failure.
- Never open nor remove the unit case to modify the unit. Refer all servicing to your nearest TOA dealer.
- Take care not to drop the unit onto the floor nor bump it against a hard object as the unit could fail.
- Do not place the unit in locations of high temperature (e.g. in an ill-ventilated car in summer) or high humidity as the unit could fail.
- Do not use the unit in locations where it is exposed to seawater.
- Avoid using a mobile telephone near the wireless microphone in use. Noise could be picked up.
- When installing, keep the unit as far away as possible from fluorescent lamps, digital equipment, personal computers, and other equipment that generate high frequency noise.
- To clean, use a dry cloth. When the unit gets very dirty, wipe lightly with a cloth dampened in a dilute neutral cleanser, then wipe with a dry cloth. Never use benzene, thinner, or chemically-treated cleaning towel.
- When using two or more wireless microphones, keep them at least 50 cm away from each other to avoid malfunctions or noise.
- Keep the wireless microphone at least 3 m away from the receiving antenna. Using the microphone in close proximity to the antenna could result in malfunctions or noise.

5. NOMENCLATURE AND FUNCTIONS

Receiver : S4.04-RX & S4.10-RXA
[Front]

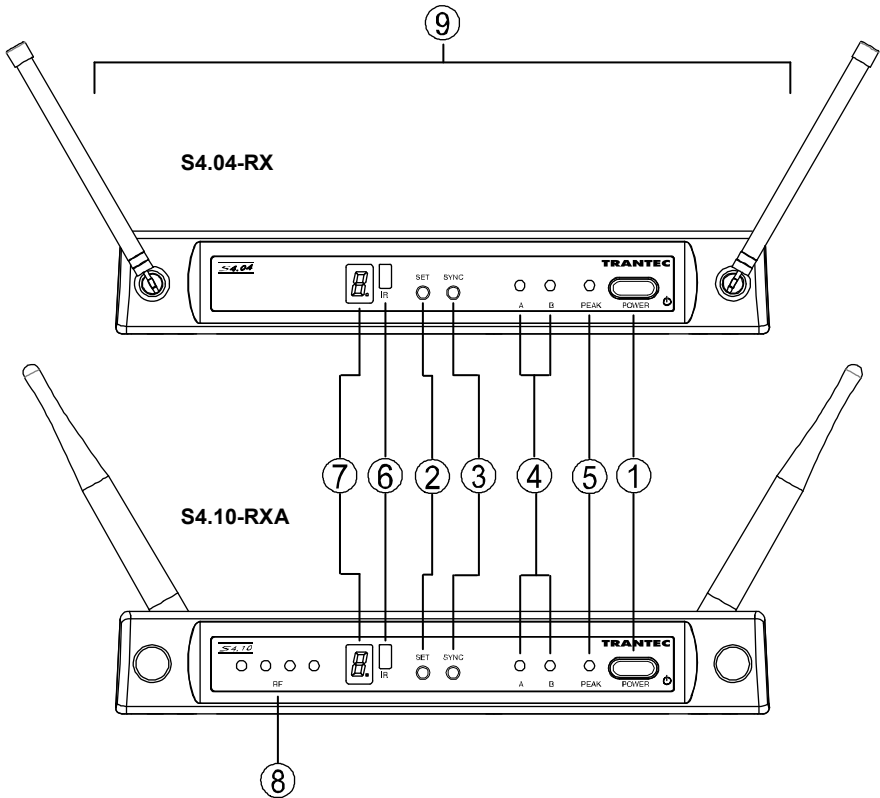

1. Power switch

Press this switch to turn the power on, and press it again to turn the power off.

2. Channel setting key [SET]

Used to select the receiving channel (frequency). (The receiver frequency must be identical to that of the microphone.)

3. Infrared (IR) sync key [SYNC]

Press this switch to transfer the frequency to the transmitter.

4. Reception lamps [A, B]

Either lamp A (left) or B (right) lights yellow when the receiver matches a radio signal from the transmitter.

5. AF peak lamp [PEAK]

Lights red when the receiver output level reaches the point about 3 dB below the clipping level.

6. Infrared (IR) port [IR]

Transmit the infrared signal, when pressing SYNC key,

7. Numerical LED display

Indicates the current channel number in normal state.

In setting mode, the indicated channel number flashes until registered.

8. RF signal level meter (S4.10-RXA only)

Indicates the RF signal level.

9. Antennas (S4.04-RX only)

Raise both antennas at 45° outwards from a vertical line.

When carrying the unit, be sure to fold down both antennas to prevent them from break.

[Rear]

S4.04-RX

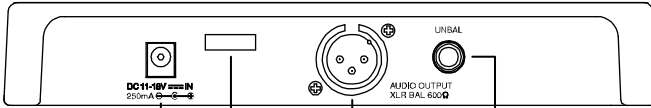

S4.10-RXA

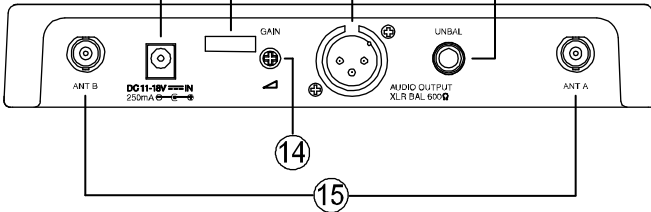

10. DC input jack

Connect the power cable of the supplied AC adapter to this jack.

11. Cable hanger

Hook the power cable onto this part.

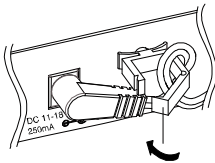

12. AF output

Balanced XLR jack, male type (Pin #2: Hot).

S4.04-RX : -20 dBu (maximum)

S4.10-RXA : 16 dBu (maximum)

13. AF output

Unbalanced phone jack

S4.04-RX and S4.10-RXA : 10 dBu (maximum)

14. Volume control (S4.10-RXA only)

Adjust the output level.

15. Antenna input A, B (S4.10-RXA only)

BNC connectors for antennas

Phantom powering for the external antenna (optional)

For the wireless system covering a relatively narrow area, use the supplied two rod antennas, which should be set up at 45° outwards from a vertical line.

Tip S4.10-RXA receiver gain is continuously adjustable. Should the receiver signal be too high, it will distort your mixer / amplifier. If the signal is too low, the result will be an increase in general background noise. Monitor the AF peak LED on the receiver, and adjust the volume control to achieve the best signal quality.

Handheld microphone : S4.04-HDX & S4.10-HDX

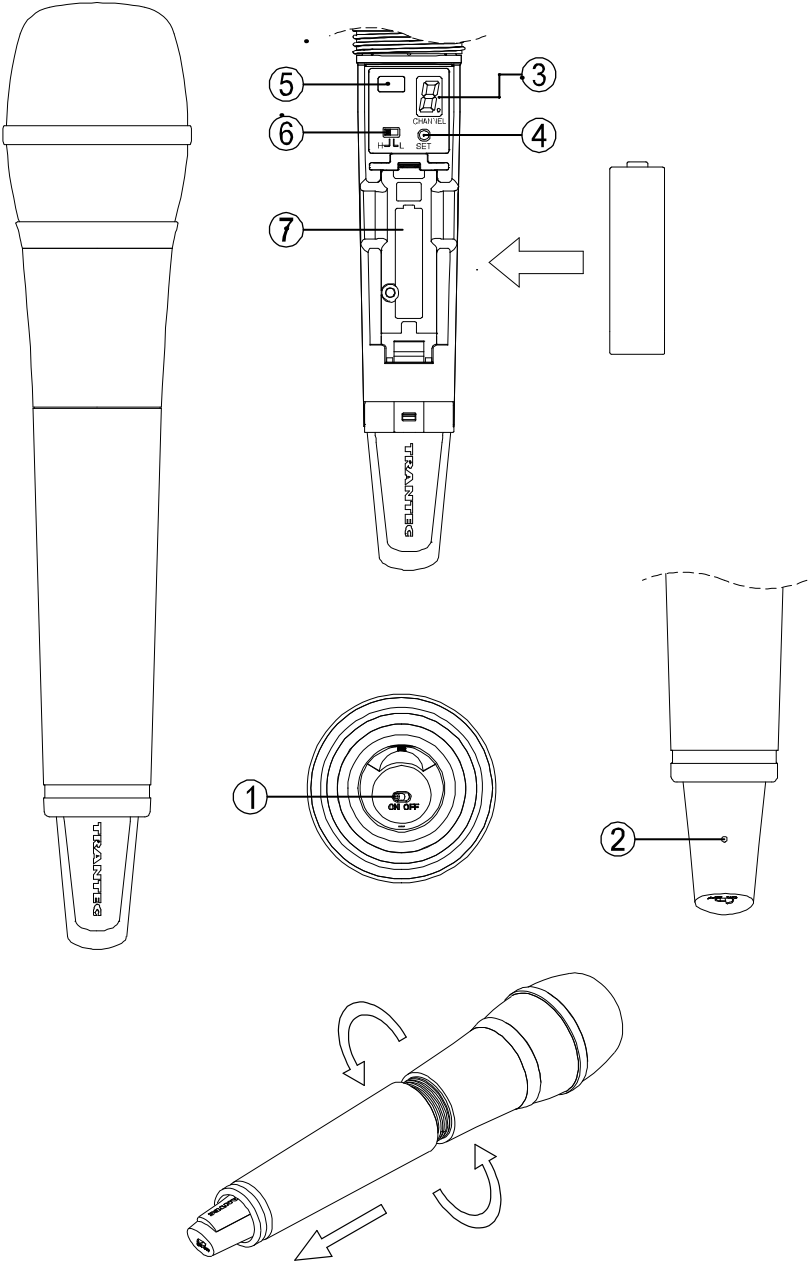

Belt-pack transmitter : S4.04-BTX & S4.10-BTX

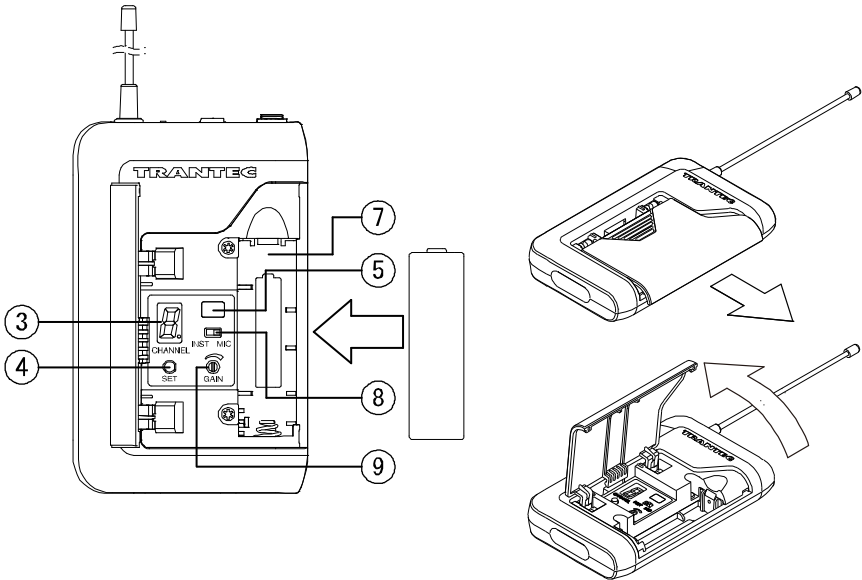
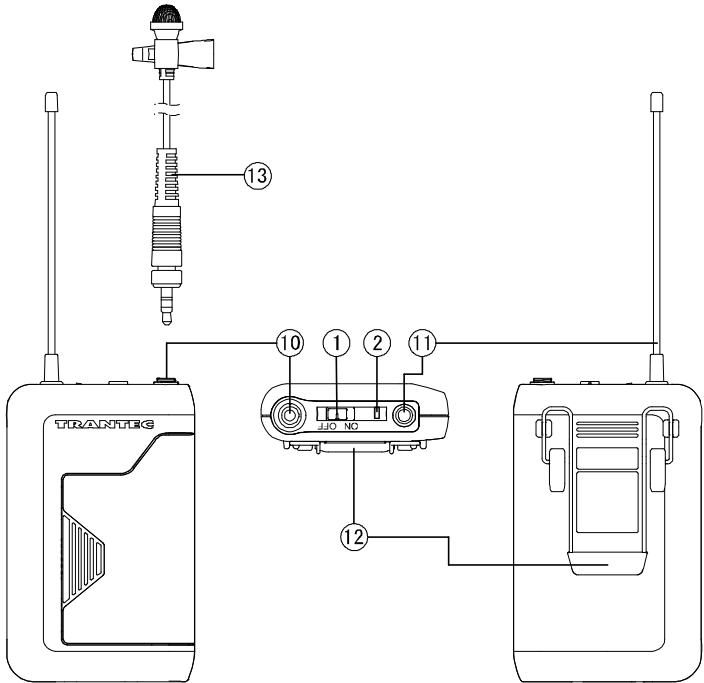

1. Power switch

Slide this switch towards "ON" to turn the power on, and slide it again towards "OFF" to turn the power off.

2. Power / Battery lamp

A green LED lights as long as the battery capacity is sufficient. When the battery capacity becomes low, the green LED starts to flash.

3. Numerical LED display

Indicates the current channel number in normal state.

In setting mode, the indicated channel number flashes until registered.

4. Channel setting key [SET]

Used to select the channel (frequency). (The frequency must be identical to that of the receiver.)

5. Infrared (IR) port

Receive the infrared signal from the receiver.

6. PAD switch (S4.10-HDX only)

This switch is used for microphone sensitivity adjustment. The sensitivity can be decreased to "H" (0dB), "L" (-10dB).

Note Never position the transmitter antenna directly against the body or hand. This will have the effect of reducing the operating range considerably.

7. Battery compartment

Insert an AA battery according to (+) and (-) indications on the battery compartment.

Note: Turn off the power switch.

HDX: Hold the microphone body and rotate the microphone grip counterclockwise to remove it.

BTX: Slide the battery cover in the direction indicated by the arrow while pressing on the cover with a thumb and hinge upwards.

8. MIC / Instrument switch (BTX only)

Slide this switch towards "MIC" to connect the microphone, and slide it towards "INST" to connect the instrument.

9. Audio level control (BTX only)

Adjust the audio level control using the supplied screwdriver. The transmitter sensitivity increases as the control is rotated clockwise, and decreases as rotated counterclockwise.

10. Input connector (BTX only)

3.5 mm jack socket, Connect the microphone or the instrument cable.

11. Antenna (BTX only)

12. Clip (BTX only)

Clip the transmitter to a belt through the belt clip.

13. Microphone (BTX only)

Note: Route the microphone cable so as to avoid undue strain or friction. Try and keep the microphone cable away from the antenna.

6. CHANNEL NUMBER SETTING by MANUAL

Step 1. Press the SET key for about 3 seconds until the displayed channel number blinks.

Step 2. Select the desired channel number with the SET key, and once the desired number is reached, release the SET key. After about 5 seconds, the receiver automatically sets channel and the blinking number turns to steady light.

Tip Continuous depression of the SET key permits the display to cycle through the channel numbers.

On the receiver side, when the dot LED by the channel number LED is blinking at selected channel number, this means that the channel is already occupied.

Note Make sure that the transmitter is identical to the receiver in the channel number. Should the microphone's setting differ from that of the receiver, the receiver will not receive the radio signal from the transmitter.

On the transmitter side, the power switch turns on, the channel number display turns on the light for about 20 seconds, and then this display turns off the light. When SET key presses in this condition, this display turns on the light for about 20 seconds.

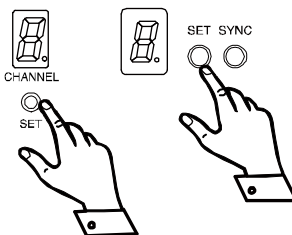

7. CHANNEL NUMBER SETTING by INFRARED SYNCHRONIZATION

Step 1. Confirm that the receiver is set to the correct channel number and the transmitter is turned the power on, then open the battery case on the transmitter.

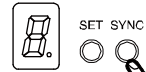

Step 2. Bring the IR port in the transmitter within 20cm of IR port on the receiver.

Step 3. Press the SYNC key on the receiver for about 3 seconds. When the channel data has transmitted successfully from the IR port on the receiver, the displayed channel number flashes.



Step 4. When the channel number is synchronized successfully between the receiver and the transmitter, the displayed channel number in the transmitter blinks for about 3 seconds,

Note On the transmitter side, even if the channel number display light turns off, the display turns on again when IR synchronization has succeeded.

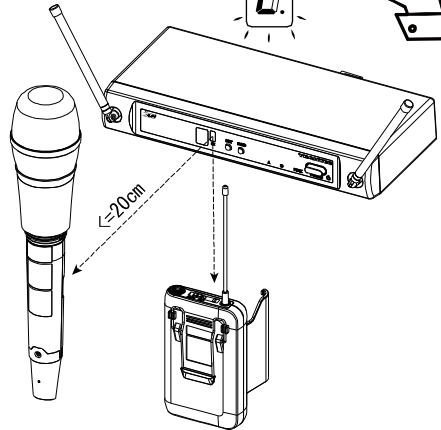

8. CHANNEL SCAN

Step 1. Press the SET key and the SYNC key at the same time for about 3 seconds. Channel scan begins, and an idle channel number is indicated blinking on the channel number display.



Step 2. After channel scan finishes, the idle channels are displayed in turn.

Step 3. Press the SET key and the SYNC key at the same time, the receiver sets the idle channel automatically.



Note Before starting the channel scan, turn off all transmitters and any other equipment that could cause interference during the setting or it may be detected during the channel scan.

If there are no idle channels, the channel number is displayed blinking as a "-". And then the channel before starting the channel scan is set again.



Multiple System Setup

Set up each system one at a time, confirm each system is assigned a different channel, and leave the transmitter powered on. Otherwise, the channel scan from the other receiver will not detect as the occupied channel.

9. BATTERY ALARM INDICATON

• When the battery capacity in the corresponding transmitter becomes low, the dot LED of the numerical LED on the receiver and the transmitter blinks. Replace the transmitter battery.



10. OPERATIONAL HINTS

- The transmitter's service distance is 3 – 100 m. When the transmitter user moves in a facility, signal dropouts (momentary losses of signal reception) may be encountered. These dropouts are caused by the building's architectural design or materials which block the travel of or reflect the radio signal. If this occurs, the user needs to change locations for better signal reception.
- Confirm the good line of sight between the transmitter and the receiver. Do not place large obstructions (e.g. Concrete walls or large metal obstructions) between the transmitter and the receiver. In addition keep the receiver away from metallic beams and obstructions as these can adversely affect the antenna pick-up pattern and cause interference.
- The proper operation of your wireless system may be interfered with by other systems operating on the same frequency. In such cases, change the operating frequency of your system.
- Hold the microphone within 20cm from the sound source. Move the microphone closer for a warmer sound. And do not cover the grille with hand.
- Keep your mouth 15 – 20 cm away from the lavalier microphone for the best possible sound reproduction. In case of the Omni-directional response, it will pick up sounds from all directions. It is better that the microphone is placed closer to the sound source. Take care not to bring your mouth too close to the microphone (within 5 cm) as this impairs speech clarity if you speak loudly.
- In case of the headset microphone, by adjusting the gooseneck, locate the microphone with the supplied windscreen in front of your mouth, and position it 3 – 5 cm away from your mouth for the best sound reproduction. When the microphone is too close to your mouth or you speak too loud, speech clarity will be impaired, making it hard for the audience to hear announcements.

11. TROUBLESHOOTING

Issue	Condition	Solution
No sound	Receiver Reception lamps [either A or B] or RF signal level meter lights.	Confirm the connections of all sound system or gain Confirm the receiver volume control.
Sound distorted	AF peak lamp [PEAK] indicates.	Confirm the transmitter gain or PAD. Confirm the receiver volume control. Confirm the receiver output level match to the input level of the mixer / amplifier.
Poor range or sound dropouts	Receiver Reception lamps [A and B] are flicking or RF signal level meter turn light off.	The system must be set up within recommended range. The transmitter must be used in line of sight from the receiver. Check the channel scan, confirm nearby source of interference, and change the receiver and the transmitter to a different channel. Confirm the battery indication, and replace the transmitter battery.

12. SPECIFICATIONS

System

Modulation	Wideband FM
Frequency Range	UHF band (506-538, 538-576, 576-603, 603-638, 638-671, 671-701, 720-758, 785-815, 819-832, 836-867, 925-937.5 MHz)
Tunable Frequencies	25 kHz Steps
Switchable Channels	S4.04 : 4 channels S4.10 : up to 16 channels (depending on region)
Operated channels simultaneously	S4.04 : 4 channels S4.10 : up to 16 channels (depending on region)
Pilot tone	32.768kHz
Total Harmonic Distortion	< 1 % @1kHz
Function	IR sync, Channel scan, Battery life information
Dynamic Range	>96 dB(A)
Operating Range	approx. 100 m
Operating Temperature Range	-10°C to +50° C

Note: 506–603 MHz and 614–698 MHz for USA/Canada, 614–698 MHz for Brazil, 865–867 MHz for India, 925-937.5 MHz for Korea

TRANSMITTER

	S4.04-HDX, S4.10-HDX	S4.04-BTX, S4.10-BTX
Microphone unit	Dynamic with cardioid pattern	TRANTEC series lavalier and head set microphone
RF Carrier Power	10 mW	10 mW
Audio Frequency Response	80 - 15000 Hz	50 - 15000 Hz
Audio input Level	140 dB SPL (maximum)	-6dBV (maximum), mic gain 0dB
Battery Life	approx. 10 hours	approx. 10 hours
Power Supply	1 AA size alkaline battery, 1.5 V	1 AA size alkaline battery, 1.5 V
Finish	Resin, coating	Resin, coating
Dimensions*	250 x ϕ 55 mm	62 (W) x 100 (H) x 25 (D) mm (with clip)
Weight*	245 g (with battery)	85 g (with battery)

RECEIVER S4.04RX, S4.10-RXA

Diversity Reception	Antenna Diversity
Sensitivity	10uV at 45dBA S/N
Squelch (SQ)	Tone SQ, Carrier SQ, Noise SQ
Audio Frequency Response	50 - 15000 Hz
Audio Output Level (Maximum)	S4.04-RX Balanced (XLR socket) : -20 dBu Un-balanced (1/4" jack socket) : 10 dBu S4.10-RXA Balanced (XLR socket) : 16 dBu Un-balanced (1/4" jack socket) : 10 dBu
Power Supply	11 - 18 VDC 300 mA
Dimensions*	215 (W) x 39 (H) x 102 (D) mm (excluding antenna and BNC)
Weight*	480g

0dBu=0.775V

Note: The design and specifications are subject to change without notice for improvement.

• Accessory

AC adapter

Microphone holder (For handheld microphone)

Screwdriver (For setting of Belt-pack transmitter)

